

# PC330-PIC

Specifications / Specifikationer / Spezifikationen

Chipper type	<b>P</b>	Pellet chipper with 360° screen (Patented)
Flisbyggertype		Pilleflisbugger med 360° sold (Patenteret)
Häckslertyp		Pelletholzhackmaschine mit 360° sieb (Patentiert)
Hydraulics	<b>I</b>	Internal (integrated pump, driven from main axle)
Hydraulik		Intern (integreret pumpe, drevet fra hovedakslen)
Hydraulik		Intern (integrierter Pumpe, von Hauptwelle angetrieben)
Chute type	<b>C</b>	Crane chute (crane feeding only)
Tragttype		Krantragt (kun til kranmadning)
Trichtertyp		Krantrichter (nur für Kranbetrieb)
Features	Remote controlled infeed rollers, no stress system, crane fixture	
Inkluderet	Fjernstyrede indtræksvalser, omdrejningsvagt, kranflange	
Enthaltent	Fernbediente Einzugswalzen, no stress system, Kranflansch	

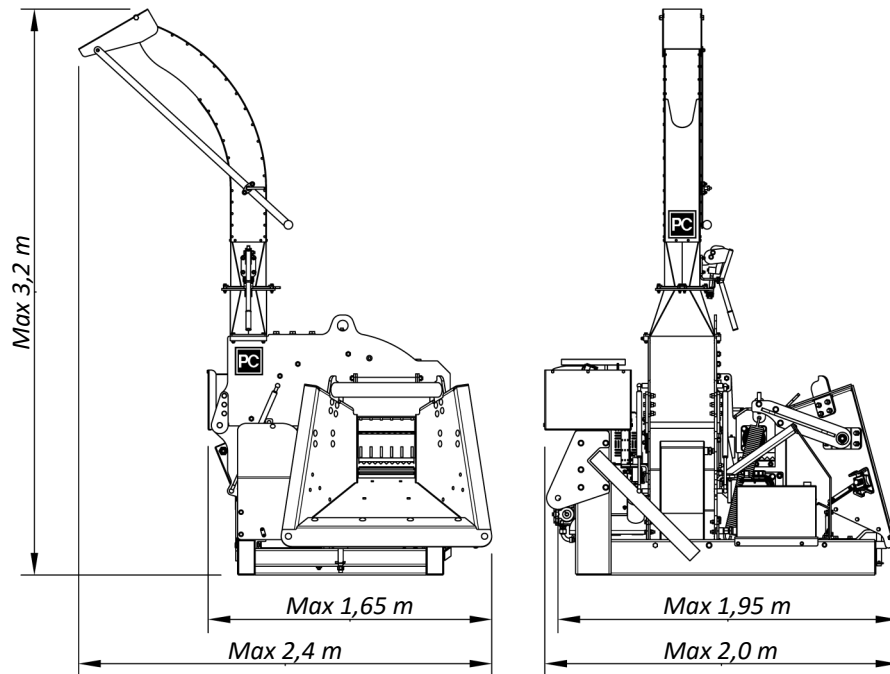

Trunk diameter (max)	<b>33</b>	cm
Trædiameter (maks.)		cm
Holzdurchmesser (max)		cm
Power requirement (min - max) at 1,000 rpm	<b>100 - 250</b>	hp (kW)
Kraftbehov (min - maks.) ved 1.000 omdr./min.		hk (kW)
Kraftbedarf (min - max) bei 1.000 UpM		PS (kW)
Weight	<b>1850</b>	kg
Vægt		kg
Gewicht		kg
Rotor weight	<b>380</b>	kg
Rotorvægt		kg
Rotorgewicht		kg
Number of chipping blades	<b>4</b>	pcs
Antal hugknive		stk
Anzahl Hackmesser		Stück
Number of screen blades	<b>4</b>	pcs
Antal soldknive		stk
Anzahl Siebmesser		Stück
Revolutions (PTO)	<b>1000</b>	rpm
Omdrejninger (PTO)		omdr./min.
Umdrehungen (PTO)		UpM
Capacity	<b>50 - 100</b>	m <sup>3</sup> /hr
Kapacitet		m <sup>3</sup> /time
Kapazität		m <sup>3</sup> /St
Spline on main axle	<b>1¾" x Z6</b>	
Spline på hovedaksel		
Spline an Hauptwelle		
Torque from infeed rollers (up to)	<b>2130</b>	Nm
Torsionsmoment fra indtræksvalserne (op til)		Nm
Drehmoment die Einzugswalzen (bis zu)		Nm

The right to changes is reserved / Der tages forbehold for ændringer / Recht auf Änderungen vorbehalten



PC Stål ApS

Håndværkervej 6  
DK • 8881 Thorsø

www.pc-staal.dk  
✉ info@pc-staal.dk  
☎ +45 86 966 566

