

PC270-SEC

Specifications / Specifikationer / Spezifikationen

Chipper type	S	Standard chipper
Flisbyggertype		Standardflisbugger
Häckslertyp		Standardhäcksler
Hydraulics	E	External (from tractor)
Hydraulik		Ekstern (fra traktor)
Hydraulik		Extern (aus Schlepper)
Chute type	C	Crane chute (crane feeding only)
Tragttype		Krantragt (kun til kranmadning)
Trichtertyp		Krantrichter (nur für Kranbetrieb)
Features	Remote controlled infeed rollers, no stress system,	
Inkluderet	Fjernstyrede indtræksvalser, omdrejningsvagt	
Enthalten	Fernbediente Einzugswalzen, no stress system	

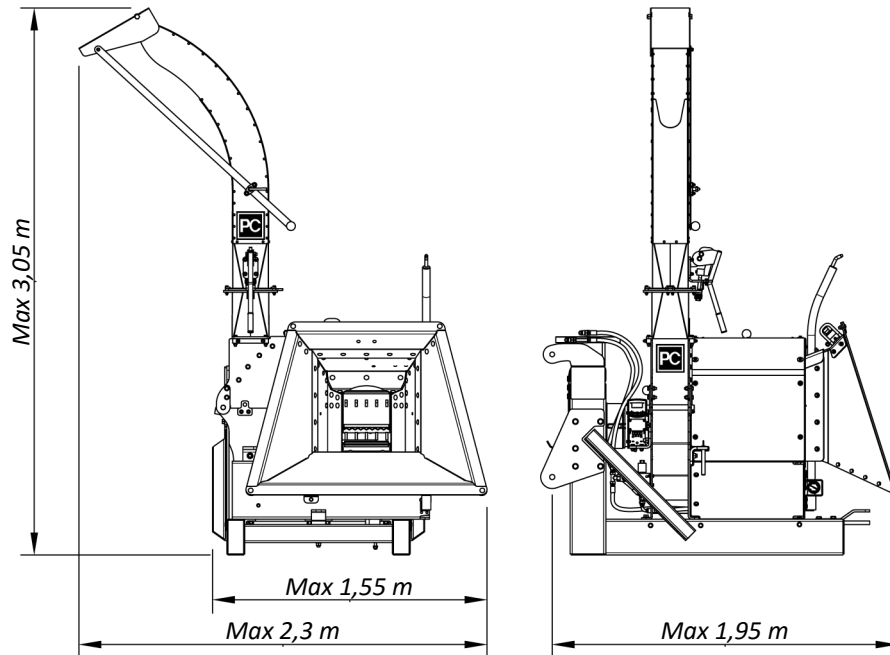

Trunk diameter (max)	27	cm
Trædiameter (maks.)		cm
Holzdurchmesser (max)		cm
Power requirement (min - max) at 540 rpm	45 - 80	hp (kW)
Kraftbehov (min - maks.) ved 540 omdr./min.		hk (kW)
Kraftbedarf (min - max) bei 540 UpM		PS (kW)
Power requirement (min - max) at 1,000 rpm	45 - 150	hp (kW)
Kraftbehov (min - maks.) ved 1.000 omdr./min.		hk (kW)
Kraftbedarf (min - max) bei 1.000 UpM		PS (kW)
Weight	1200	kg
Vægt		kg
Gewicht		kg
Rotor weight	300	kg
Rotorvægt		kg
Rotorgewicht		kg
Number of chipping blades	4	pcs
Antal hugknive		stk
Anzahl Hackmesser		Stück
Revolutions (PTO)	540 / 1000	rpm
Omdrejninger (PTO)		omdr./min.
Umdrehungen (PTO)		UpM
Capacity	30	m ³ /hr
Kapacitet		m ³ /time
Kapazität		m ³ /St
Spline on main axle	1 3/4" x Z6	
Spline på hovedaksel		
Spline an Hauptwelle		
Torque from infeed rollers (up to)	1096	Nm
Torsionsmoment fra indtræksvalserne (op til)		Nm
Drehmoment die Einzugswalzen (bis zu)		Nm

The right to changes is reserved / Der tages forbehold for ændringer / Recht auf Änderungen vorbehalten



PC Stål ApS

Håndværkervej 6
DK • 8881 Thorsø

www.pc-staal.dk

✉ info@pc-staal.dk

☎ +45 86 966 566

STANDARD