

# PC200-SEH

Specifications / Specifikationer / Spezifikationen

Chipper type	<b>S</b>	Standard chipper
Flisbyggertype		Standardflisbugger
Häckslertyp		Standardhäcksler
Hydraulics	<b>E</b>	External (from tractor)
Hydraulik		Ekstern (fra traktor)
Hydraulik		Extern (aus Schlepper)
Chute type	<b>H</b>	Chute for hand feeding
Tragttype		Tragt til håndmandning
Trichtertyp		Trichter für Handbeschickung
Options	No stress system	
Ekstraudstyr	Omdrejningsvagt	
Extrausstattung	No stress system	

Trunk diameter (max)	<b>20</b>	cm
Trædiameter (maks.)		cm
Holzdurchmesser (max)		cm
Power requirement (min - max) at 540 rpm	<b>35 - 60</b>	hp (kW)
Kraftbehov (min - maks.) ved 540 omdr./min.		hk (kW)
Kraftbedarf (min - max) bei 540 UpM		PS (kW) (26 - 45)
Power requirement (min - max) at 1,000 rpm	<b>35 - 114</b>	hp (kW)
Kraftbehov (min - maks.) ved 1.000 omdr./min.		hk (kW)
Kraftbedarf (min - max) bei 1.000 UpM		PS (kW) (26 - 85)
Weight	<b>950</b>	kg
Vægt		kg
Gewicht		kg
Rotor weight	<b>135</b>	kg
Rotorvægt		kg
Rotorgewicht		kg
Number of chipping blades	<b>4</b>	pcs
Antal hugknive		stk
Anzahl Hackmesser		Stück
Revolutions (PTO)	<b>540 / 1000</b>	rpm
Omdrejninger (PTO)		omdr./min.
Umdrehungen (PTO)		UpM
Capacity	<b>20</b>	m <sup>3</sup> /hr
Kapacitet		m <sup>3</sup> /time
Kapazität		m <sup>3</sup> /St
Spline on main axle	<b>1¾" x Z6</b>	
Spline på hovedaksel		
Spline an Hauptwelle		
Torque from infeed rollers (up to)	<b>1096</b>	Nm
Torsionsmoment fra indtræksvalserne (op til)		Nm
Drehmoment die Einzugsvalzen (bis zu)		Nm

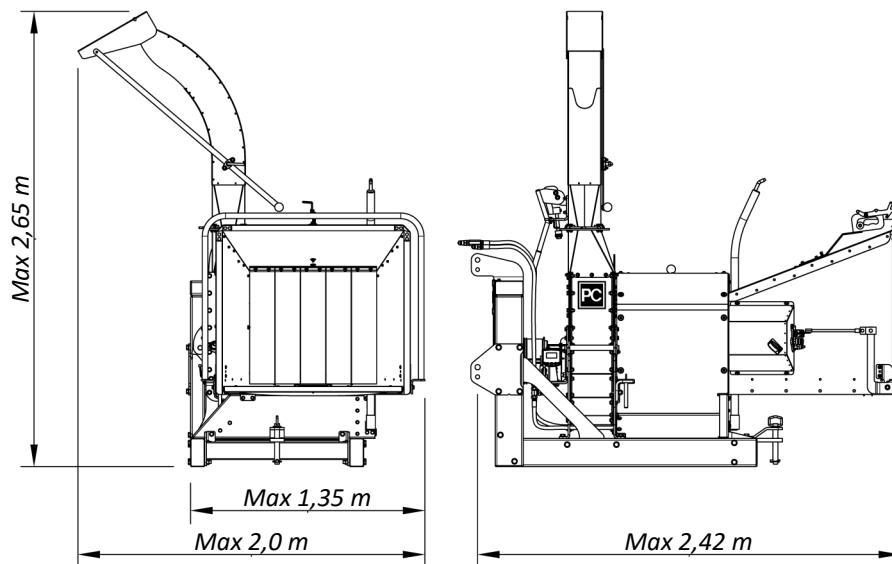

The right to changes is reserved / Der tages forbehold for ændringer / Recht auf Änderungen vorbehalten



PC Stål ApS

Håndværkervej 6  
DK • 8881 Thorsø

www.pc-staal.dk

✉ info@pc-staal.dk

☎ +45 86 966 566

**STANDARD**