

PC150-SEH

Specifications / Specifikationer / Spezifikationen

Chipper type	S	Standard chipper
Flisbyggertype		Standardflisbugger
Häckslertyp		Standardhäcksler
Hydraulics	E	External (from tractor)
Hydraulik		Ekstern (fra traktor)
Hydraulik		Extern (aus Schlepper)
Chute type	H	Chute for hand feeding
Tragttype		Tragt til håndmandning
Trichtertyp		Trichter für Handbeschickung
Options	No stress system	
Ekstraudstyr	Omdrejningsvagt	
Extraausstattung	No stress system	

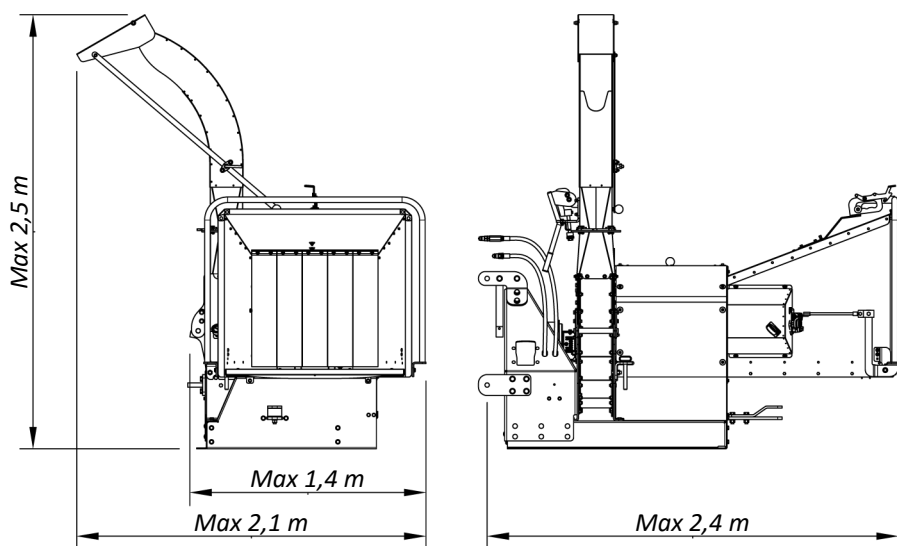

Trunk diameter (max)	15	cm
Trædiameter (maks.)		cm
Holzdurchmesser (max)		cm
Power requirement (min - max) at 540 rpm	25 - 50	hp (kW)
Kraftbehov (min - maks.) ved 540 omdr./min.		hk (kW)
Kraftbedarf (min - max) bei 540 UpM		PS (kW)
Power requirement (min - max) at 1,000 rpm	25 - 85	hp (kW)
Kraftbehov (min - maks.) ved 1.000 omdr./min.		hk (kW)
Kraftbedarf (min - max) bei 1.000 UpM		PS (kW)
Weight	690	kg
Vægt		kg
Gewicht		kg
Rotor weight	124	kg
Rotorvægt		kg
Rotorgewicht		kg
Number of chipping blades	2	pcs
Antal hugknive		stk
Anzahl Hackmesser		Stück
Revolutions (PTO)	540 / 1000	rpm
Omdrejninger (PTO)		omdr./min.
Umdrehungen (PTO)		UpM
Capacity	10	m ³ /hr
Kapacitet		m ³ /time
Kapazität		m ³ /St
Spline on main axle	1 3/4" x Z6	
Spline på hovedaksel		
Spline an Hauptwelle		
Torque from infeed rollers (up to)	640	Nm
Torsionsmoment fra indtræksvalserne (op til)		Nm
Drehmoment die Einzugsvalzen (bis zu)		Nm

The right to changes is reserved / Der tages forbehold for ændringer / Recht auf Änderungen vorbehalten



PC Stål ApS

Håndværkervej 6
DK • 8881 Thorsø

www.pc-staal.dk

✉ info@pc-staal.dk

☎ +45 86 966 566

STANDARD